

DTA/MS INVESTIGATIONS OF METAL COMPLEXES WITH ACETOACETANILIDES

A.A. KETTRUP, K.H. OHRBACH, G. RADHOFF and W. KLUSMEIER

Department of Chemistry, Applied Chemistry, University of Paderborn, P.O. Box D-4790 Paderborn (Federal Republic of Germany)

(Received 5 September 1983)

ABSTRACT

A coupling system is introduced and discussed for the combination of a simultaneous TG-DTA apparatus with a quadrupole mass spectrometer. The function of this combined system is demonstrated by the thermal degradation of metal complexes and by simultaneous investigation of their fragmentation patterns in the mass spectrometer.

INTRODUCTION

The authors are engaged in the synthesis of selective complexing compounds and selective ion exchangers for the enrichment and analysis of metal ions. It has been pointed out that substituents on the ligand molecule influence the stability of the metal complexes.

Acetoacetanilide (Fig. 1) was chosen for the systematic investigations. In this molecule the hydrogen atoms of the phenyl group as well as the hydrogen of the methylene group can be substituted. The phenyl ring-substituted acetoacetanilide was found to be especially suitable as a complexing agent.

Further mass spectrometric investigations of the fragmentation patterns of metal chelates have indicated that the number and abundance of metal-containing fragment ions increase with increasing stability of the metal chelates [1-3]. Calculation of the ratio of the abundance of metal-free and metal-containing fragments gives a measure of the stability of metal chelates.

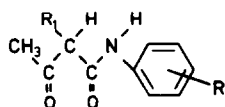

Fig. 1. Structure of acetoacetanilide.

$$Q = \frac{\Sigma I(\text{fragment} + \text{Me})}{\Sigma I(\text{fragment} - \text{Me})}$$

The ratio is influenced by substituents of the ligand molecule. At this point of our investigations we are interested in determining the influence of substituents on the ligand molecule on the thermal degradation of metal chelates. For these investigations a system consisting of a Netzsch STA 429 TG-DTA apparatus and a Balzers QMG 511 quadrupole mass spectrometer was chosen.

EXPERIMENTAL CONDITIONS

In simultaneous TG-DTA-DTG equipment coupled with a mass spectrometer, the following two operating modes, which depend on pressure relations, have to be distinguished:

- (1) high vacuum in the thermoanalyzer and mass spectrometer;
- (2) atmospheric pressure in the thermoanalyzer, high vacuum in the mass spectrometer.

The second operating method, in particular, requires a complicated interface for pressure reduction, situated between the test space of the thermoanalyzer and the analyzer of the mass spectrometer. A quadrupole system has been selected as an analyzer for the investigation of mass distribution in the gas atmosphere. The simple, room-saving construction of a quadrupole mass filter, and the sufficient resolving capacity, even at a rapid mass scan, render the quadrupole mass spectrometer well suited to combination with a thermoanalyzer. A Balzers mass filter was used for the mass range 1-511, with variable operating possibilities via a digital electronic control system. The mode of operation can be described as follows.

(1) In the mass range of interest, up to 12 fixed mass units (m/z) can be registered simultaneously with respect to their dependence on the temperature with an optimum selected sensitivity.

(2) A pre-selectable mass range can be scanned once or repeatedly with scan speeds between 0.1 ms/mass unit and 30 s/mass unit.

(3) Total pressure is measured in a pre-selected mass range with information on the contribution of the most frequent masses or fragment ions to the total pressure.

High vacuum is realized with a turbo-molecular pump. In this way a low background and no hydrocarbons of a pumping oil are established. The coupling interface between the thermoanalyzer and the mass spectrometer fulfils two functions: it operates simultaneously as a gas input system for the quadrupole mass filter, and as a pressure reduction system, if the pyrolytic decomposition of a sample occurs in a gas atmosphere.

The gas inlet system for a mass spectrometer combined with a thermo-

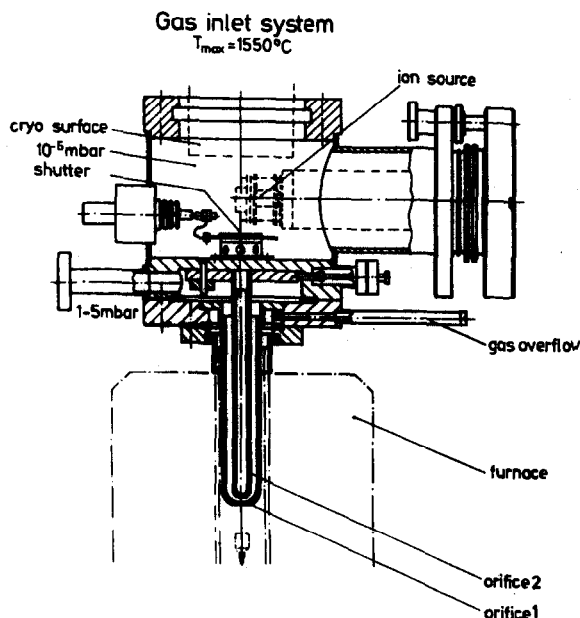

Fig. 2. Gas inlet system with orifices of Al_2O_3 .

gravimetric apparatus working up to 1550°C sets high requirements on material and mechanical precision. The majority of our thermogravimetric tests were carried out at atmospheric pressure in the test space in air and nitrogen. The gas inlet system for the mass spectrometer should bring all gases and vapours released from the sample unaltered to detection and analysis in the mass spectrometer. During the decomposition of a sample in high vacuum the distance and geometric arrangement of the ionization device of the mass spectrometer towards the vaporizing sample are decisive in order to transform the arising molecular stream most effectively into a detectable ion beam. While during high-vacuum operation the detection sensitivity of a mass spectrometer is scarcely used, the partial pressure sensitivity of the mass spectrometer specifies the detection limits for measurements under atmospheric pressure.

The Netzsch STA 429 coupling system with a Balzers QMG 511 mass spectrometer consists of a two-stage gas inlet system. The pressure reduction of atmospheric pressure on the sample, which decomposes by emitting gas or vaporizes, up to the high vacuum required in the recipient of the mass spectrometer is accomplished by orifices arranged in Al_2O_3 tubes (Fig. 2) [4].

RESULTS AND DISCUSSION

In order to test the DTA/MS system organometallic compounds of which most data are well known from previous publications were prepared [5]:

TABLE 1

Relative peak area values for beryllium chelates

Series of beryllium chelates	Relative peak areas
bis(Acetoacetanilide)Be(II)	1.00
bis(<i>p</i> -Acetoacetoluidide)Be(II)	2.20
bis(<i>m</i> -Acetoacetoluidide)Be(II)	1.80
bis(<i>o</i> -Acetoacetoluidide)Be(II)	2.05
bis(<i>p</i> -Acetoacetanisidide)Be(II)	2.37
bis(<i>m</i> -Acetoacetanisidide)Be(II)	2.18
bis(<i>o</i> -Acetoacetanisidide)Be(II)	1.80
bis(<i>p</i> -Acetoacetchloranilide)Be(II)	1.72
bis(<i>m</i> -Acetoacetchloranilide)Be(II)	1.63
bis(<i>o</i> -Acetoacetchloranilide)Be(II)	1.40

Be-(acetoacetanilide)₂, various substituents;
 metal-(acetylacetonate)₂, various metals;
 metal-(immobilized chelates).

In the study of the thermal behaviour of the beryllium acetoacetanilides the stability was compared from TG and DTA, depending on the influence of the substituent. Therefore the relative peak areas from the DTA curve were taken from the unsubstituted compound and all substituted metal complexes discussed in the present work, see Table 1.

In all cases the experimental parameters (especially the DTA sensitivity 0.05 mV) were the same. These values have been correlated with other experimental data of the metal chelates, corresponding to the stability of the complexes in solution.

Figure 3 shows good correlation between the relative $\Delta\Delta H$ values and the pK_D values of the chelating agent, showing increasing complex stability with increasing pK_D values.

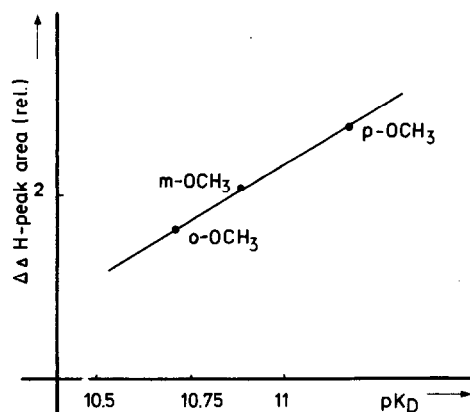

Fig. 3. Correlation between the relative peak areas and the dissociation constants of the ligands.

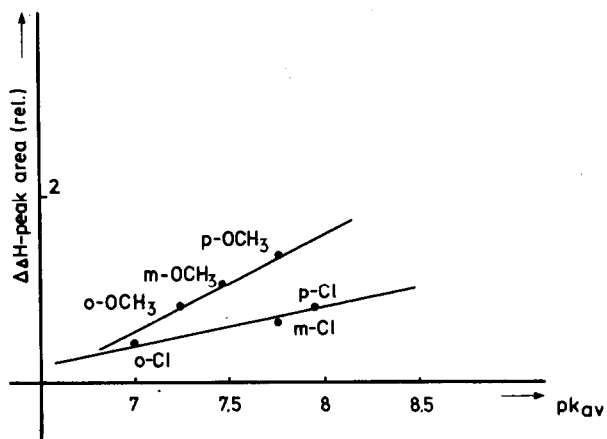

Fig. 4. Correlation between the relative peak areas and the average stability constants of the beryllium chelates.

A plot of the pK_{av} values vs. the relative $\Delta\Delta H$ values shows the same order of stability as expected (Fig. 4). The slope of the straight line is remarkably influenced by the kind of substituent, as shown in Fig. 4. The two straight lines show higher slope for the methoxy substituents than for the chlorine substituents.

A typical TG–DTA curve is presented in Fig. 5 for bis(*o*-acetoacetyluidide)Be(II). Melting of the complex takes place at 187°C (460 K), indicated

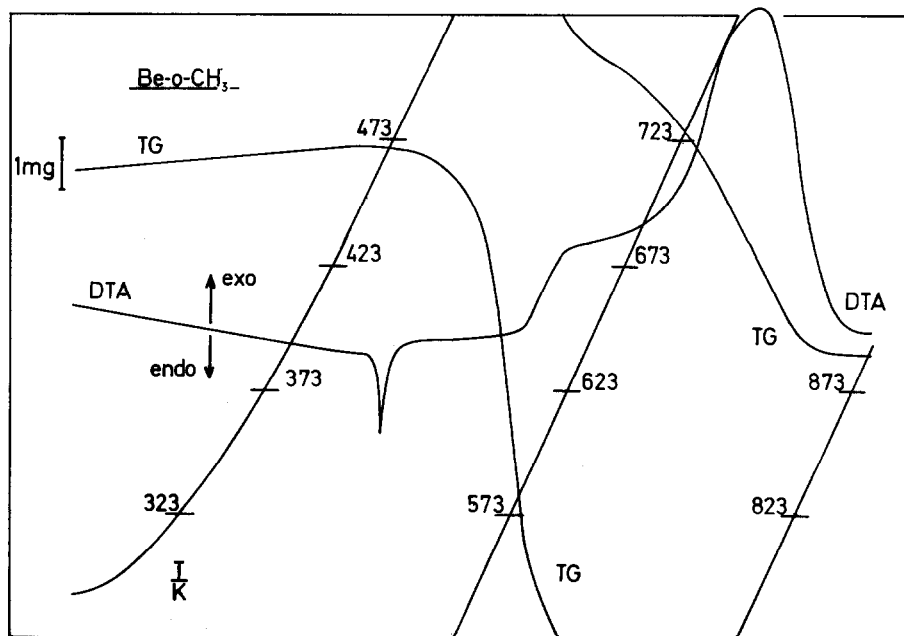

Fig. 5. TG–DTA curve of bis(*o*-acetoacetyluidide)Be(II).

by a sharp endothermic peak in the DTA curve, followed by oxidative decomposition, which occurs in two stages. This is indicated by one maximum at 440°C (713 K) and a shoulder at about 360°C (633 K) in the DTA curve.

Fragmentation behaviour of beryllium-acetoacetanilides by high-resolution mass spectrometry has been discussed previously of special interest in the present work was the investigation of the applicability of the TG-DTA-MS system to the above-mentioned problem, in a dynamic air atmosphere in the TG-DTA apparatus. The combined system allows also mass identification of volatile decomposition products using different inert gases, as pyrolytic thermal analysis up to 1800 K.

During cleavage of the metal-ligand bond, ions of lower masses were produced corresponding to the decomposition of the free ligand, which is shown below. Although it was not possible to record the molecular ion, in many cases the loss of one ligand and the metal containing complementary ion in the mass range of about 190 to 220 u was obtained. The occurrence of the aniline cation, due to the cleavage of the α -bond by proton transfer, was evident in each of the mass spectra. By cleavage of the α -bond and following McLafferty rearrangement the fragment ions (a) and (b) were produced.

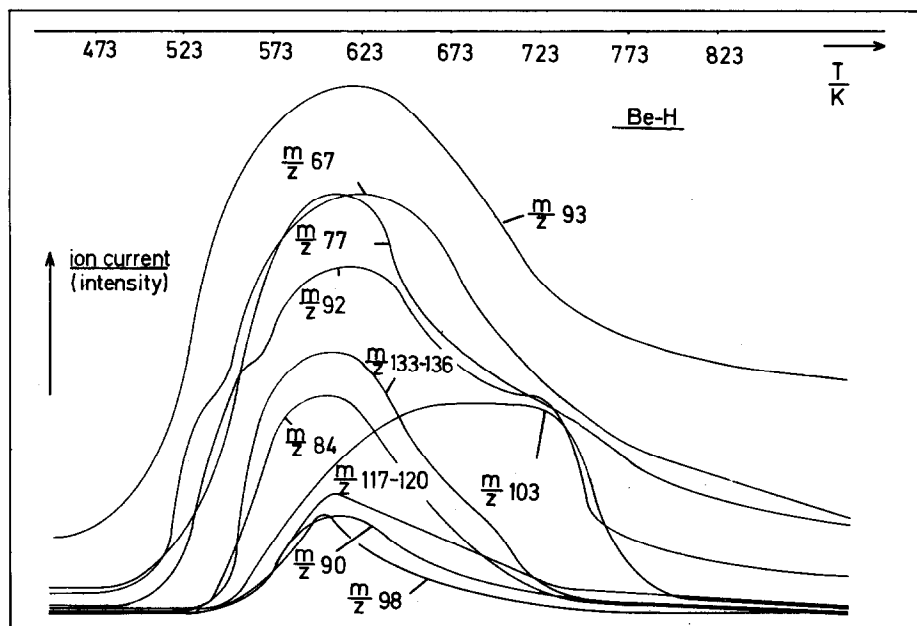
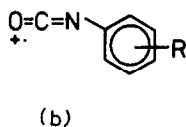
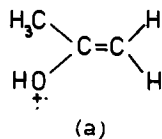

Fig. 6. Ion current of selected mass fragments of the Be-H complex.



These ion-radicals may also recombine with free metal cations, while another degradation of the fragment (a) produces the acyl cation. Formation of the acyl cation takes place during the thermal decomposition of all metal complexes. It is formed by fragmentation of a ligand cation from the chelate followed by fragmentation of the ligand cation. One special field of interest was the observation of the thermal degradation as a function of temperature. The 12-channel point printer was used to record the TG-MS data and simultaneous operation of the TG-DTA apparatus. The diagram shows the initial course of the ion currents with selected mass numbers (Fig. 6). The spectrum was scanned with a scan speed of 3 s/mass unit and various sensitivities of the mass spectrometer. Vaporization of the sample Be-H occurs in the temperature range 500–800 K, with a maximum at 620 K. The inserted mass of Be-acetoacetanilide was 20 mg and the heating rate 5 K/min. The experiment was stopped when no significant changes in the TG 2 weighing curve were observed at a temperature near 870 K.

The occurrence of metal-free and metal-containing products was observed whereas the metal-free fragments were predominant in all spectra, which means that heating bis(acetoacetanilide)Be(II) lowers the metal carbonyl-oxygen bond followed by the loss of one ligand cation and subsequent fragmentation of the ligand.

REFERENCES

- 1 A. Kettrup, P. Ackermann and W. Riepe, *Z. Naturforsch., Teil B*, 33 (1979) 183.
- 2 A. Kettrup and W. Riepe, *Z. Anal. Chem.*, 252 (1970) 1.
- 3 A. Kettrup and K.-H. Ohrbach, *Angew. Chem. Thermodynamik und Thermoanalytik, Experientia Supplementum 37*, Birkhäuser Verlag Basel, 1980.
- 4 W.D. Emmerich and E. Kaisersberger, *J. Therm. Anal.*, 17 (1979).
- 5 K.H. Ohrbach, G. Radhoff and A. Kettrup, *Fresenius Z. Anal. Chem.*, 314 (1983) 398.